

TMB Optical TMB-80CF

Thomas M. Back Signature Series

Congratulations on your purchase of the TMB-80CF carbon fiber body FPL-53 ED apochromatic triplet refractor. Its exceptional optical and mechanical quality will provide you with many years of highly portable observing and imaging enjoyment.

MOUNTING POSSIBILITIES

Your TMB-80CF is usable with many different telescope mounts. It comes with two 90mm felt-lined hinged split mounting rings that have five 1/4"-20 thread holes drilled and tapped into the top and bottom of each ring. You can use these to install the scope directly on many German equatorial mounts, or on a telescope mount dovetail plate such as those from Losmandy or Vixen. They also let you mount an accessory plate on top of your scope.

A quality altazimuth mount, such as the Astro-Tech Voyager or Vixen Porta mount, would also be a good choice for grab-and-go visual use. Either mount can be used with the TMB-80CF simply by adding a Vixen-style dovetail plate to the tube rings.

FOCUSER

Your focuser is a backlash-free dual-speed 2" Feather Touch Crayford from Starlight Instruments. Its drawtube terminates in a 2" compression ring accessory holder to allow visual use with 2" accessories and imaging with large format CCD cameras. The non-marring soft brass compression ring won't scratch your 2" star diagonal barrel as an ordinary thumbscrew can.

There is also a 2" to 1.25" compression ring adapter for visual use with 1.25" accessories and for imaging with standard format CCD, webcam, and 35mm photo adapters. Its barrel is threaded to accept standard 2" filters and has a slight taper at the top that engages the compression ring of the 2" adapter. This prevents the 1.25" adapter from slipping out of the focuser should the two 2" accessory holder thumbscrews accidentally loosen during use.

Your focuser has two coarse focusing knobs. The right knob has a smaller concentric knob with a 10:1 reduction gear microfocusing ratio. This provides precise focusing during high magnification visual observing and critical 35mm or CCD imaging. The focus knobs have ribbed gripping surfaces so they are easy to operate, even while wearing gloves or mittens in cold weather.

Because the focuser is so smooth in operation and moves so freely, it can only hold a limited amount of weight (generally about 1 lb.) without drifting out of focus when the focuser drawtube is tilted vertically. The focuser therefore contains an adjustable tension internal brake system to allow astrophotography (and visual use with heavy eyepieces) without the possibility of focus shift.

A knob under the focuser lets you adjust the tension on the drawtube to accommodate differing equipment payloads. If the thumbscrew is turned all the way in (only 1 to 1½ turns), the drawtube is locked in position for long exposure astrophotography. Partial tightening of the knob offers a virtually infinite range of braking force to accommodate various eyepiece weights for visual use.

FINDERSCOPE MOUNTING

Your scope's carbon fiber body does not have any attachment points for a finderscope bracket. However, the 1/4"-20 holes in the top of the tube mounting rings offer several possible mounting locations for an optional finderscope. However, it is worth noting that the scope's short focal length, combined with the wide fields of many eyepieces, makes the TMB-80CF its own best finderscope. For example, a 2" 40mm TMB Paragon eyepiece on the TMB-80CF yields a wide 5.4° field at 12.6x, thereby converting the scope into the optically finest 80mm superfinder ever made.

COOL DOWN TIMES

For any optical system to perform at its best, the optics must be at or very near the air temperature. The "cool down" time needed to reach this ambient temperature varies considerably, as the scope

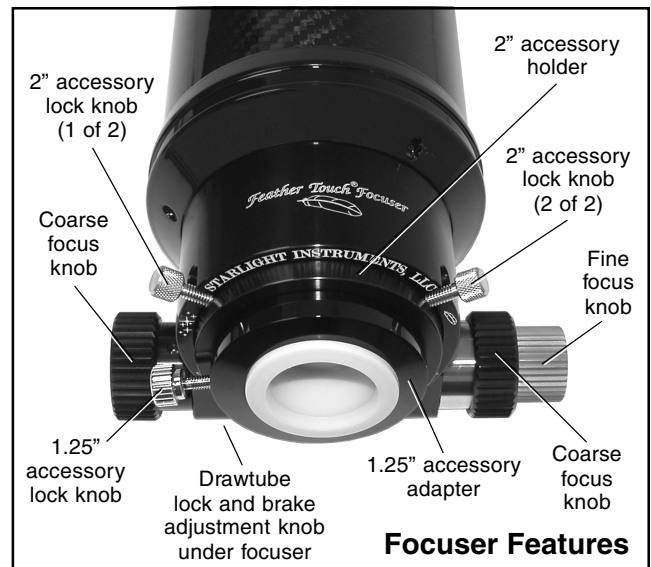

Focuser Features

temperature must change from a typical indoor temperature of 72° Fahrenheit to an outdoor temperature that can range from a high of over 100° down to 10° below zero or less. In 80mm refractors, the cool down (or heat up) time in most situations is often quick, usually less than 30 minutes. In subfreezing temperatures, though, it may take an 80mm refractor twice that time or more to reach peak performance. This is particularly true with a triplet like the TMB-80CF, where the thermal load of the center lens is isolated from the open air by the lenses on either side of it. This slows the transfer of the center lens heat load to the outside air.

If you'd like to shorten the wait to reach thermal equilibrium, placing the telescope in an unheated garage for an hour or two before observing can shorten the cool down process considerably. Another technique is to retract the dew shield to allow direct exposure of the lens to the night air so it can reach thermal equilibrium faster. Once the lens has cooled, extend the dew shield again. This provides a faster cool down time, and generally will still keep the lens from dewing up. Only on the highest dew point nights will the objective lens form dew on its front optical surface.

The dew shield is oversized, with a 124mm o.d. compared to the 80mm lens diameter and 90mm tube diameter. This assures that tube currents, which typically follow the walls of telescope tubes and dewshields, will be out of the 80mm light path for the most part and will have only a minimal effect on your images as your scope cools down to ambient temperature. You can begin serious observing sooner with your TMB-80CF than you can with an aluminum tube 80mm triplet with a conventional dew shield design. A lock knob built into the dew shield lets you lock the dew shield firmly in place so it can't slip down while aiming at the zenith.

The best way to avoid dew forming on the lens after you bring the scope into the house is to take your closed scope case outside when you observe, so it can also reach ambient temperature. When you are finished observing, cap the telescope with its dust caps and place it into the carrying case. Bring it into the house and let it slowly warm back up to room temperature, then remove the dust caps to allow any trace of dew to evaporate. Once the objective is free from dew, replace the dust caps and store the scope away.

CLEANING

The best policy is not to let the lens get dirty and/or dusty in the first place. The regular use of the dust caps is highly recommended. However, no amount of preventative measures will keep your ob-

jectively from eventually collecting dust and airborne pollutants on the first optical surface. We recommend that you do not clean the objective too often, no matter how frequently the urge to do so may hit you. A few specks of dust on the lens will not be visible in your images, as they are not in the focal plane and don't block enough light to measure, let alone be seen.

Depending on how often you use your scope, and the amount of pollutants in your air, you may have to clean your scope optics as often as twice a year, but generally no more than that – and preferably no more than once a year. If the front lens surface becomes dusty, smeared, or shows fingerprints or any other surface build-up, and you find it absolutely necessary to clean the lens, use the following cleaning technique.

First, gently blow away any surface dust or particles with a clean air blower (a child's ear syringe or a photographer's camel's hair brush with attached blower bulb, for example). The use of canned or compressed air should be avoided, if possible, as the propellant in the can may spit out and leave difficult-to-remove deposits on your lens. If you *must* use compressed air to remove stubborn particles, use a high quality compressed air duster (of the R-134 propellant type). Do not tip or shake the can. Blow any loose particles off the lens surface using short blasts at an angle to the glass, without getting too close to the lens surface or aiming directly at it.

Next, moisten a ball of USP grade pure cotton with a few drops of a photographic-quality optical cleaning solution designed for multicoated camera and binocular lenses. You can use Formula MC (available from many telescope dealers) or make your own mixture of distilled water and a drop or two of mild soap. A well-worn 100% cotton handkerchief also works well and Zeiss and Kodak both make suitable cleaning fluids. Blot the entire surface with the dampened cotton ball or cloth to pick up any stubborn particles and to clean the surface. Exchange the cotton ball and/or turn the cloth frequently so you always have a clean portion of the cotton ball or cloth in contact with the lens.

Use only a drop or two of liquid – not so much that the fluid could be wicked between the lenses by capillary action. Do not drip the cleaning fluid directly on the lens. Do not, at any stage, apply hard pressure. Using a fresh piece of cotton or a lint-free white facial tissue, carefully clean the surface of the lens by wiping from center to edge in a radial direction. Repeat the process with denatured alcohol, using a blower brush to clean off any dust that may fall on the lens as you clean it.

For the extremely fastidious, a final cleaning pass using high-grade acetone will restore the lens surface to new condition. You may notice a few faint streaks from the dried solvent. They will not affect performance, but they can be removed with light pressure and a Q-Tip slightly moistened with a small amount of alcohol or acetone. A clean air blower will remove any remaining dust.

Avoid overcleaning your scope. The multicoatings on the lens are quite hard and durable. However, frequent overzealous cleaning can scratch the coatings if all the dust particles (which are often tiny flecks of windborne rock) are not removed before you start pushing a damp tissue around the lens surface. Clean your optics only when absolutely necessary. If you take proper care of your TMB-80CF, optics cleaning should rarely be needed.

The optical tube and dew shield of the your TMB-80CF are made of a high strength woven carbon fiber cloth encapsulated in a transparent high gloss epoxy. The herringbone weave of the carbon fiber cloth is easily seen through its clear epoxy coating. The carbon fiber cloth is laid down by hand during the manufacturing process, so a subtle seam along the length of the tube is sometimes visible where the edges of the herringbone weave cloth meet.

The scope can become smudged with fingerprints during use, but these will not harm the finish. A clean soft cloth slightly dampened with plain water (or a little moisture from your breath and a

quick wipe with a clean handkerchief) is generally enough to remove fingerprints. Avoid abrasives, harsh chemical cleaners, or organic solvents like benzene, alcohol, etc., as these may dull and ruin the finish. They can certainly affect the optical coatings if they accidentally drip or splash on the objective lens.

THE STAR TEST

We strive to make the best apochromatic optical systems available. You may find your lens may not test "perfect" during an extended and stringently-graded "star test," particularly if the scope has not fully reached thermal equilibrium before the test. This is not an indication of a poor optic, but is rather due to the test star's complex wavefront continually changing as the seeing conditions in our living atmosphere vary from moment to moment. No optic is perfect, and every brand and model scope will show some error in an extended star test. The sensitivity of the star test under *perfect* conditions is 1/20th wave P-V on the wavefront for third order aberrations, and 1/60th wave for sharp (fifth order) aberrations. It is highly unlikely that even the most ardent observer can see errors of this small a magnitude on an extended object, even under very good seeing conditions (which is when the atmosphere typically presents a 1/4th wave P-V wavefront to the instrument).

The refractor also presents another factor: the change in spherical aberration with a change in wavelength found in all refractors (sphero-chromatism). As a lens is tested in the longer (red) wavelengths, the lens becomes "under-corrected." Tested in the shorter wavelengths (blue), the lens becomes "over-corrected." These overlapping corrections at different wavelengths change every refractor star test pattern from perfection.

However, TMB objectives are corrected at the peak visual wavelength centered around 560nm in the green-yellow portion of the visual spectrum. The eye sees over 80% of the visual detail at this wavelength. It is the correction at this visual peak that makes the difference between a merely good objective and a superb one. Our lenses are figured for the best possible wavefront at green-yellow wavelengths, for the sharpest images and highest contrast.

While star tests are interesting and useful, most observers spend their nights enjoying extended and detailed objects, not simply examining sharply-focused points of light. We feel that the proof of optical excellence is in the *observing*, not just in the testing.

A FINAL WORD

Thank you for your purchase of our TMB-80CF. We believe this apochromatic triplet refractor will outperform any other telescope type, inch for inch, in real-world observing and is the most trouble-free telescope that you can buy. With a little care, it will last you a lifetime. Use it often to enjoy the wonders of the night sky!

BRIEF SPECIFICATIONS

Aperture	80mm (3.1")
Focal Length	504mm
Focal Ratio	f/6.3
Objective Type	triplet apochromatic, FPL-53 ED element
Optical coatings	fully multicoated
Resolving Power (Dawes' Limit)	1.45 arc seconds
Visual Limiting Magnitude	12.0
Light Grasp Versus the Eye	131x
Focuser	Starlight Instruments <i>Feather Touch</i> #2025 2" dual-speed Crayford with 10:1 ratio fine focus and both 2" and 1.25" compression ring eyepiece holders
Focuser Travel	2.56" (65mm)
Tube Diameter	90mm (3.5") o. d.
Tube Length (lens shade retracted)	15.25" (387mm)
Tube Length (lens shade extended)	18.5" (470mm)
Optical Tube Weight	5.1 lbs. (2.32 kg)
Optical Tube Weight with tube rings	6.9 lbs. (3.14 kg)
Case Dimensions	22.75" x 9" x 7.5"

TMB Optical, Cleveland, OH 44131

E-mail: TMBoptical@aol.com